

## Car Park Fixtures Surface Mount Key Lockable & Removable



Tactile Systems Australia range of Cast in Bollards are ideal for protecting both people and property.

Our bollards are manufactured to our high-quality standards and specifications.

All bollards are manufactured from high grade steel, then hot dip galvanised, before being powder coated to give a long lasting robust finish.

These cast-in bollards are ideal for new construction use or can be retrofitted into existing substrates if necessary. Retrofit use will require a core hole to be made in the existing substrate.

- Removable with lifting handle
- Galvanised sleeve for inground portion
- Lockable

### SPECIFICATIONS

Bollard Size	Code
1000mm x 90mm	BRM-90-YEL

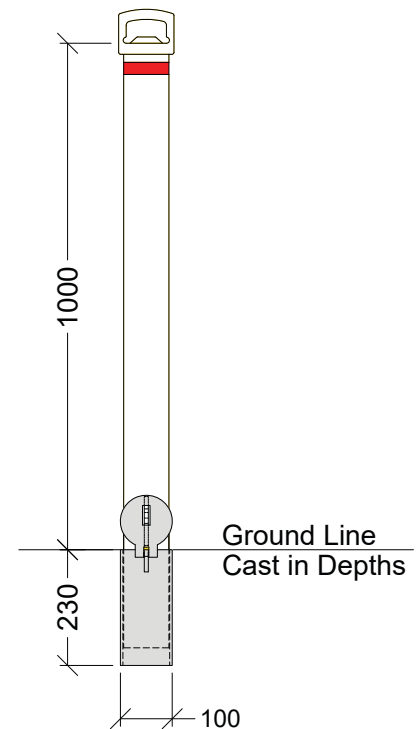

1 YEAR PRODUCT WARRANTY



INSTALLATION SERVICE AVAILABLE