

Warning Integrated TGSi Future-Tech



AS/NZ 1428.4.1 2009
STANDARD



P5 SLIP RATING NATA
APPROVED LAB



5 YEAR PRODUCT
WARRANTY



INSTALLATION SERVICE
AVAILABLE



REQUIRES 30%
LUMINANCE CONTRAST
Testing Service Available

COLOUR VARIATIONS

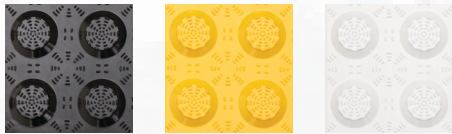

SPECIFICATIONS

Black	WIFT-30X60-TSA-BLK
White	WIFT-30X60-TSA-WHI
Yellow	WIFT-30X60-TSA-YEL

SUITABLE SUBSTRATES

Tiles	Carpet	Bitumen
Timber	Rubber	Concrete
Vinyl	Pavers	Exp Aggregate

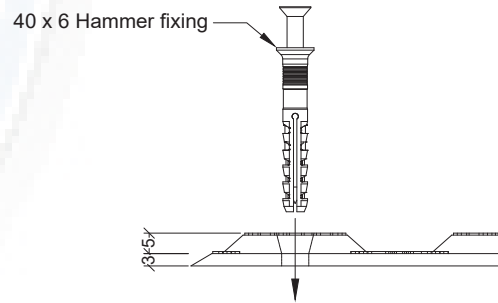
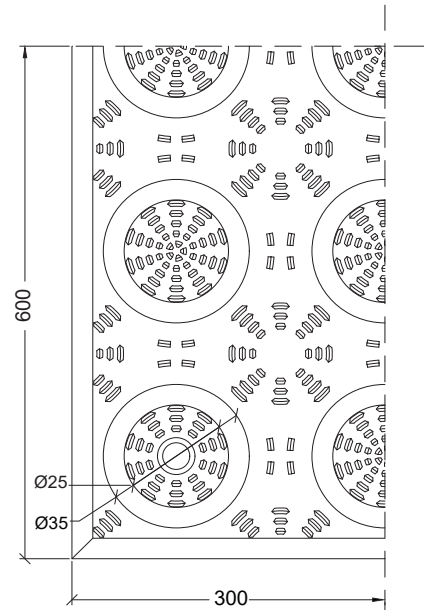

Warning Integrated TGSi Future-Tech

Tactile Systems Australia's Warning Integrated Future-Tech surface mount TGSi are designed for years of use in the harshest environments. They are highly impact resistant feature good UV stability to ensure they remain colourfast for years of service. Manufactured using very high grade engineered polymers,

Future-tech TGSi are fully compliant with the AS/NZ 1428.4.1 2009 standards which feature excellent slip resistance, a P5 rating as tested by a NATA Approved Laboratory.

Features

- AS 1428.4.1 2009 Compliant design
- P5 Slip rating
- Beveled edges to reduce trip hazards
- Fast installation, pre formed fastener locations for optimal fixing
- Installed using adhesive as well as mechanical fixings to give years of dependable service
- Suitable for a wide range of substrates, consult with highly trained professionals with regards to colour selections and luminance contrast for your project.

Product Material Description

Future-Tech TGSi Panels are made from a sheet moulding compound based on unsaturated polyester resin. The product is glass fibre reinforced and contains mineral fillers. In case of fire the product doesn't melt, neither does it form droplets nor is smoke generation excessive. The material is compression moulded in heated steel molds. The product contains no halogens or heavy metals nor any candidates from the REACH SVHC list.

TYPICAL PRODUCT PROPERTIES

	Standard	Units	
Density	ISO 1183	g/cm ³	1,9
Shrinkage	ISO 2577	%	-0,05
Heat Distortion Temp.	EN ISO 75-2	°C	>200
Continuous Service Temp.	Menzolit	°C	165
Young's Modulus	EN ISO 527-4	GPa	11
Tensile Strength	EN ISO 527-4	MPa	90
Flexural Strength	EN ISO 14125	MPa	180
Flex Modulus	EN ISO 14125	GPa	10
Impact Strength	EN ISO 179	kJ/m ²	80
Glow Wire Index	IEC 60707-3	°C	
Fire Retardant	UL 94		
Surface Resistivity	IEC 60093	Ohm	1012
Comparative Tracking Index	IEC 60112	Level	CT1600
Water Absorption	ISO 62	%	< 0,5

Properties given are the mean value of test results, and taken from non pigmented, compression moulded panels at room temperature.



AS/NZ 1428.4.1 2009
STANDARD



P5 SLIP RATING NATA
APPROVED LAB



5 YEAR PRODUCT
WARRANTY



INSTALLATION SERVICE
AVAILABLE



REQUIRES 30%
LUMINANCE CONTRAST
Testing Service Available