

Car Park Fixtures Downpipe Protector

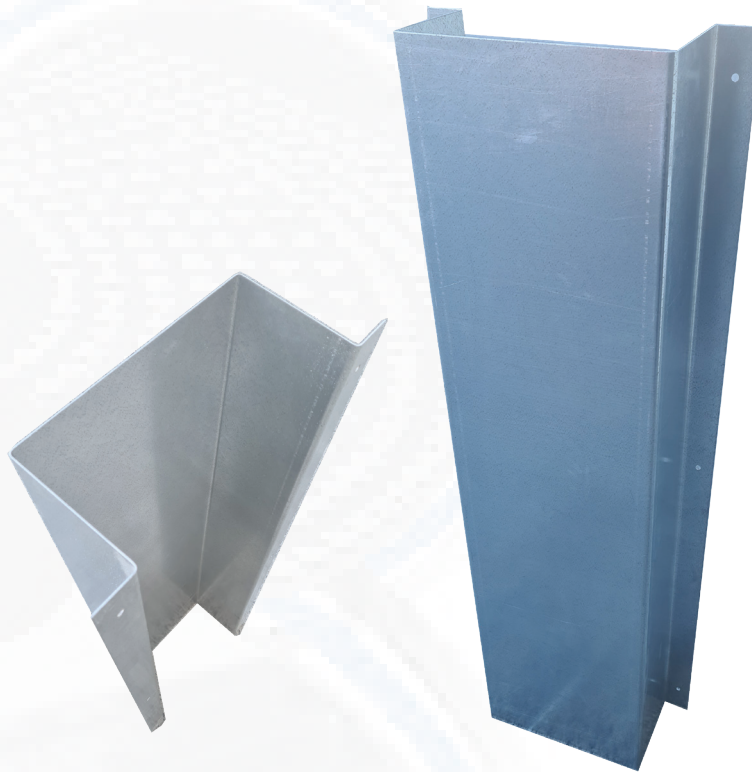

Downpipe Protectors from Tactile Systems Australia are ideal for guarding against damage to your pipes. Made from galvanised steel with pre drilled holes they are easy to install. Available in a standard size 1200x150x150-2mm or custom sizing. We also have the option of powder coating with your choice of colour.

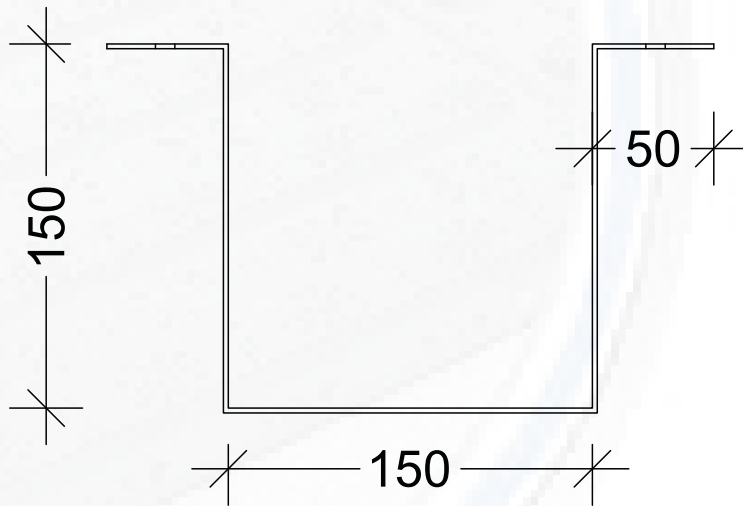

1 YEAR PRODUCT
WARRANTY



INSTALLATION SERVICE
AVAILABLE

Specifications

Type	Code	Size
Standard	DPS-150-GAL	1200x150x150-2mm